



# Electronic-drain valve

## Descriptions

The electronic drain valve is composed of a valve, a filter ball valve and a timer. Instruction manual outlines installation procedure. The electronic drain valve is suitable for all compressed air system components (after-coolers, dryers, filters, pressure vessels and piping), regardless of their size, or capacity - simply adjust the interval and discharge times to suit the particular compressed air system.

The filter ball valve is unique in the fact that the valve has an integrated ball valve strainer. It offers all the advantages of a timer controlled drain and in addition has the protection of a mesh strainer, preventing large particles from blocking the valve orifice. The unit can be shut off from the compressed air system enabling safe maintenance work to be carried out.

## Specifications

Time setting		Solenoid valve	
Interval time	0.5-45m. adjustable	type	2position&2port
Drain time	0.5-10s adjustable	In/out connection	1/4 , 3/8 , 1/2 flare
Voltage	AC/DC24-220-380V +10%	Working pressure	1.6Mpa,4.0Mpa,8.0Mpa
Amps.	Max.4mh	Medium Temp.	90°C
Environment Temp.	-4 50°C	Valve body	Forged brass
Protection grade	IP65	Defend grade	IP65
Material	ABS	Insulation grade	H class
Electronic connection	DIN43650A ISO 4400/6952	Orifice	4.50mm(high pressure 2.0mm)
indicator light	Green-on Red-off	Mounting Positions	Horizontally or Vertically

### Gentle Automatic Solution Sdn Bhd

36,Jalan Industri USJ1/13,Taman Perindustrian USJ 1, 47600 Subang Jaya, Selangor Darul Ehsan, Malaysia.

Tel : + 603 - 8023 7743 / + 603 - 8023 8743

Fax : + 603 - 8023 9743

Mobile Number : + 6012 - 273 8827 / + 6012 - 2206172 / + 6017 - 3397388

Email : [sales@gentle.com.my](mailto:sales@gentle.com.my)

## Appearance

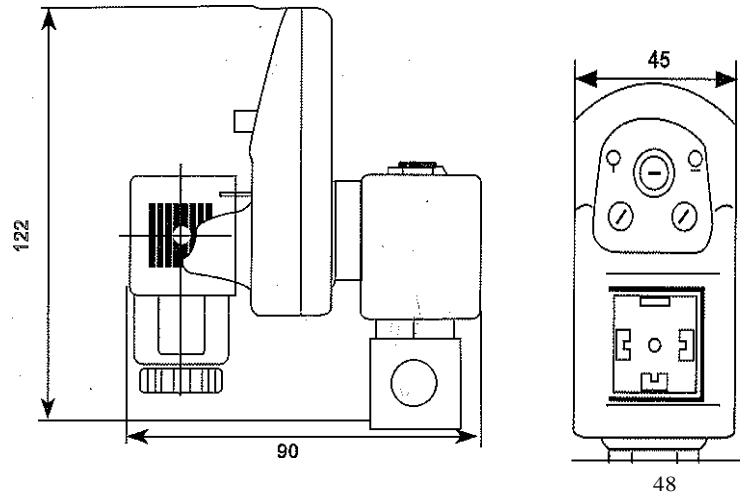

## Mounting:

### 1. Valve

When mounting the valve, the direction of arrow on the valve body must be the same as the flowing of the condensate. The outlet of the valve should be put a container to collect the condensate.

### 2. Connection of the time setting

The electrical wire must be three-core jacket cable, diameter is 8mm. Turn-on the screw of the top, take off the junction box, be care of the earthing wire, then connect the wire. After connecting, the screw down the wire-screw and the top screw nut.

### 3. Time setting

The right side is interval time and the left side is draining time. Generally speaking, draining time is setting 2s, while interval time is setting 20m. It can be adjustable according to your requirements.

## Notice:

1. Before installing, make sure the system is clean, not containing impurity. It is better that after 3 to 5 minutes while the system is under full pressure, install the valve.
2. The direction of flow are the same as the arrow on the valve body.
3. Voltage of the system are the same as the electronic coil.
4. TEST button on the time setting is a manual button. Once it is pressed, the valve drain. This button is used to test drain in daily work.
5. There are two knobs can adjust the time of drain and interval. It can be adjustable according to climate and working.
6. The screw on the junction box must be screw tightly for fear that time setting & electronic coil are easily broken.
7. Maybe during the daily work of the valve, electronic-drain valve will leak, that is because core of valve is blocked. That is condensate is too dirty, which make little solid get into the valve. If this happens, please do as follows:
  - (1) Turn-on the power, set the draining time at 0.5s, then knob the TEST button time after time until it is OK. (This way is useful for the little block)
  - (2) Or else, dismantling the valve (do not need to dismount the valve out of the system):
    - 1) Close the isolated ball valve, knob the TEST button to make sure the electronic drain valve is insulated from the system (under 0 pressure).
    - 2) Cut off the power.
    - 3) Take off the coil, open the valve and take out the core and spring, use water to wash. And then, install. That is OK.

## Gentle Automatic Solution Sdn Bhd

36, Jalan Industri USJ1/13, Taman Perindustrian USJ 1, 47600 Subang Jaya, Selangor Darul Ehsan, Malaysia.

Tel : + 603 - 8023 7743 / + 603 - 8023 8743

Fax : + 603 - 8023 9743

Mobile Number : + 6012 - 273 8827 / + 6012 - 2206172 / + 6017 - 3397388

Email : [sales@gentle.com.my](mailto:sales@gentle.com.my)